

- Medprirobnična krogelna pipa iz ogljikovega jekla
- Wafer carbon steel ball valve

KPA-G IZ OGLJIKOVEGA JEKLA / KPA-G CARBON STEEL

// Polni pretok / Full bore

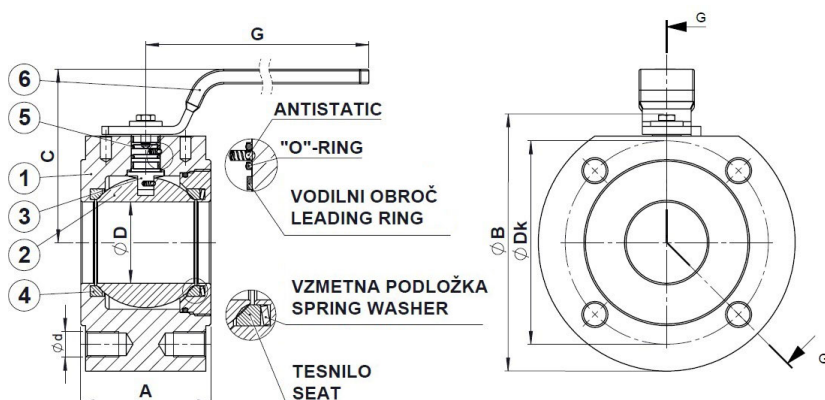
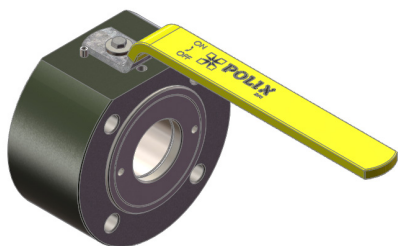

Materiali / Materials

1	Ohišje Body	Ogljikovo jeklo – A105, P235TR2 Carbon Steel – A105, P235TR2
2	Krogla Ball	Nerjavno jeklo - 1.4301 (X5CrNi18-10) AISI 304 Stainless steel - 1.4301 (X5CrNi18-10) AISI 304
3	Vreteno Stem	Nerjavno jeklo – 1.4028 (X30Cr13) AISI 420 Stainless Steel – 1.4028(X30Cr13) AISI 420
4	Tesnilo krogle Ball seats	Teflon – PTFE
5	O-Obroč O-Ring	Viton (+60 °C) - FKM
6	Ročica Handle	Ogljikovo jeklo (cinkano) – S235JR (St 37-2) Carbon steel (galvanized) – S235JR (St 37-2)

Navor / Torque

DN	Maks. navor Max torque P = 16 bar T = 20°C	Maks. navor Max torque P = 40 bar T = 20°C	Priporočljivi navor za pogon Recommendable torque for actuator
	[Nm]	[Nm]	[Nm]
15	6	10	20
20	8	15	20
25	15	20	30
32	20	30	45
40	25	40	60
50	35	55	80
65	45	80	120
80	60	100	150
100	90	150	200
125	180	350	450
150	250	500	700
200	400	700	1000

Opombe: Navori so bili izmerjeni s čisto vodo pri sobni temperaturi na ventilih s PTFE tesnili. Navor se lahko poveča pri ventilih, ki imajo tesnila iz drugačnih materialov, pri merjenju z različnimi tekočinami, višjimi temperaturami, posebnimi obratovalnimi pogoji in/ali v primeru, da je ventil dlje časa pod diferenčnim tlakom, ne da bi obratoval.

Remarks: The torques were measured on valves supplied with virgin PTFE seats, with clean water at room temperature. For valves with other seat material, different fluids, higher temperatures, specific operating conditions and/or in case the valve is kept for a long time under differential pressure without being operated, the torque can increase.

// Delovna temperatura / Working temperature: -20 °C/+60 °C

(Za temperature nižje od -20 °C kontaktirajte proizvajalca /
For temperature below -20 °C please contact manufacturer)

Diagram tlak I temperatura / Pressure I temperature chart

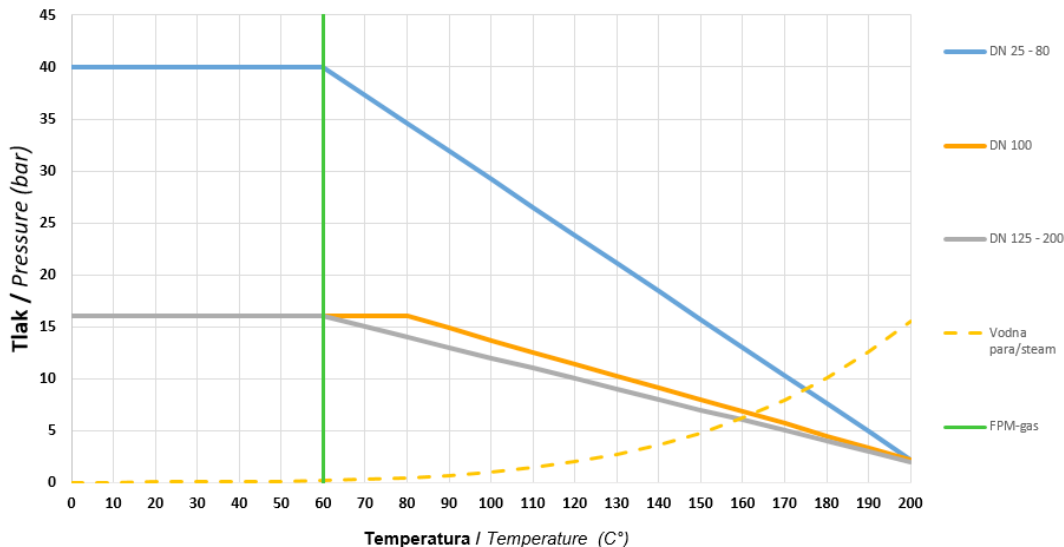

Tesnila vreteno, ohišje / Stem, body seals

FPM-gas (Max 60°C)

KPA-G DN ... PN16 DP VX PX

PN16

Art.	DN	A	ØB	C	ØD	G	ØDk	Ød	Št./Nr.	Teža / weight [kg]
A955071	15	39	88	80	16	150	65	M12	4	2,80
A955072	20	39	98	80	20	150	75	M12	4	2,90
A955073	25	48	110	76	25	158	85	M12	4	3,00
A955074	32	55	130	108	32	180	100	M16	4	4,50
A955075	40	65	140	114	40	180	110	M16	4	6,50
A955076	50	80	150	128	50	222	125	M16	4	11,00
A955077	65	100	175	160	63,5	293	145	M16	4	15,00
A955078	80	120	190	170	78	293	160	M16	8	20,00
A955079	100	140	220	185	99	293	180	M16	8	28,50
A955080	125	175	296	194	125	541	210	M16	8	35,00
A955081	150	210	330	213	150	541	240	M20	8	97,00
A955082	200	270	435	310	200	1000	295	M20	12	179,00

KPA-G DN ... PN40 DP VX PX

PN40

Art.	DN	A	ØB	C	ØD	G	ØDk	Ød	Št./Nr.	Teža / weight [kg]
A955083	65	100	175	160	63,5	293	145	M16	8	15,00
A955084	80	120	190	170	78	293	160	M16	8	20,00
A955085	100	140	220	185	99	293	190	M20	8	28,50

Opombe

Številke artiklov od DN15–DN50 so enake za PN16 in PN40 in so vedno navedene kot PN40.
Antistatična izvedba in požarno tesnilo.
Nadgradnje na strani 89 - 95.

Notes

Article numbers for DN15–DN50 are the same for PN16 and PN40 and are always declared as PN40.
Antistatic and fire safe design.
Upgrades on pages 89 - 95.

O₂

Na zahtevo možna izdelava za kisik.
Ball valves for oxygen available upon request.