

TRZ2

Turbine gas meters DN 50 - 150 for custody transfer



Applications

Gas measurement at low and high operating pressures

Brief information

Elster-Instromet TRZ2 turbine gas meters are robust meters for use in stationary conditions. Over years they have proved themselves to be highly accurate and reliable devices for measuring the flow of gaseous substances.

With the patented Elster-Instromet measuring cartridge it is possible to save service time by replacement of the cartridge on site.

The measuring cartridge is supported with O-rings, is free of tension and is, therefore, not affected by any influences stemming from the housing or the ambient conditions such as temperature fluctuations.

Principle: The gas flowing through the meter sets a turbine wheel in motion and the number of revolutions of the wheel is proportional to the passed volume. The gas entering the meter is accelerated by a special designed and patented flow guide, located at the meter inlet. This flow guide is designed in such a way that any potential flow disturbances such as swirl or asymmetric flow are eliminated. Because the flow velocity is increased, the driving impulse on the turbine wheel is also strengthened. This means that it is possible to achieve a high accuracy within the permissible error limits, even with low flow rates. The flow onto the turbine wheel is axial and the wheel is run on the main shaft with robust dimensioned ball bearings.

The revolution of the turbine wheel is reduced by a gear. Via a magnetic coupling, a transmission shaft drives the 8-digit mechanical roller counter located in the pressureless totalizer head. After the gas has passed the turbine wheel, a pressure recovery is achieved in the outlet channel, which is designed to create optimum flow conditions.

Conformity: Elster-Instromet TRZ2 meters are manufactured in accordance with DIN EN ISO 9001:2000 and DIN EN ISO 14001. They are designed, produced and tested in accordance with the following guidelines, standards and references:

- EC Directive 97/23/EC concerning pressure equipment
- EC Directive 94/9/EC concerning explosion protection
- EC Directive 71/318/EC concerning to gas volume meters
- Applied European standards (et al. EN 12261)
- OIML provision R 6, R31 and R 32

All manufactured meters are tested by official, PTB approved test rigs. Test certificates in accordance with PED requirements are available for pressure and strength tests.

Material: The housings are made of GGG-40 (ductile iron) or steel. The meters meet the highest safety standards and are fire-proof (HTB).

Main features

- Turbine gas meters with measuring cartridge
- Meter types G 65 - 1000
- Flow range 5 - 1600 m³/h
- Diameters DN 50* - 150 (2" - 6")
- Pressure rates PN 10 - 100 and ANSI 150 - 600
- Temperature range -20 °C to +60 °C (further temperature ranges on request)
- Manual oil pump (standard for PN 25 - 100 and ANSI 300 - 600)
- Compact installation, inlet pipe length $L \geq 2$ DN
- Length 3 DN
- Thermowell built into meter housing (optional)
- Integrated HF-pulsar (optional)
- Absolute-ENCODER S1 (optional)
- EC and different national approvals (e.g. PTB)
- Media: natural gas, petroleum gas, town gas, nitrogen, argon, further gases on request

* DN 50/2" without patented flow guide (inlet pipe length $L > 5$ DN required)

TRZ2: Turbine gas meters for custody transfer

S1 index (standard)

- 8-digit mechanical counter
- Totalizer head can be rotated 350°
- Protection class IP67
- Absolute-ENCODER S1 (optional) useable as main meter index



Pulsers

Low frequency: Elster-Instromet TRZ2 turbine gas meters are fitted with two low-frequency pulsers and one switch for monitoring any attempts at manipulation (PCM). The low-frequency pulses, which are generated by Reed switches in the plug-in pulser IN-S1x, are used to transmit the actual volume in m³ to a volume corrector, for example. The maximum frequency is 0.5 Hz.

Standard version:

- **IN-S10** with a 2.5m open-ended 6-wire cable.

Options:

- **IN-S11** with a 6-pin flange plug and a connector socket (Binder 423 system).
- **IN-S12** with two 6-pin flange plugs and two connector sockets (Binder 423 system).

High frequency (optional): If higher pulse rates or a higher resolution is required for control or regulation purposes, the turbine meter can be equipped with high-frequency pulsers. A special feature of the Elster-Instromet TRZ2 is the fact that there are two separate systems:

- **A1S** picks up the blades of the turbine wheel.
- **A1R** picks up reference boreholes in the turbine wheel.

Up to 4 high-frequency pulsers can be ordered for the individual meter models.

The plugs for the high-frequency pulsers are designed to save space. They are located at an angle on the side of the housing and can be rotated.

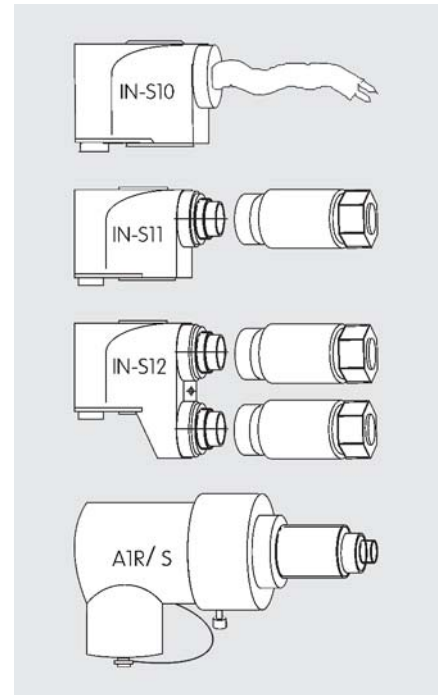

Absolute-ENCODER S1 (optional)

The Absolute-ENCODER S1 is a mechanical index, whereby the meter reading is opto-electronically scanned and transferred to the supplementary device via an electrical interface (e.g. EK260 volume corrector). Thus the Absolute-ENCODER index is an ideal combination of the advantages of mechanical and electronic indexes.

The procedure is certified by the German PTB.

The Absolute-ENCODER S1 does not require a power supply as the input is provided via the electrical interface of the supplementary device.

Available interface variations:
NAMUR, M-Bus and SCR

The Absolute-ENCODER S1 is also available as a clip-on index for a mechanical drive.



Accuracy

Limits

According to standard EN 12261:

± 1.0% for $0.2Q_{\max}$ to Q_{\max}
 ± 2.0% for Q_{\min} to $0.2Q_{\max}$

Optional half deviation limit:

± 0.5% for $0.2Q_{\max}$ to Q_{\max}
 ± 1.0% for Q_{\min} to $0.2Q_{\min}$

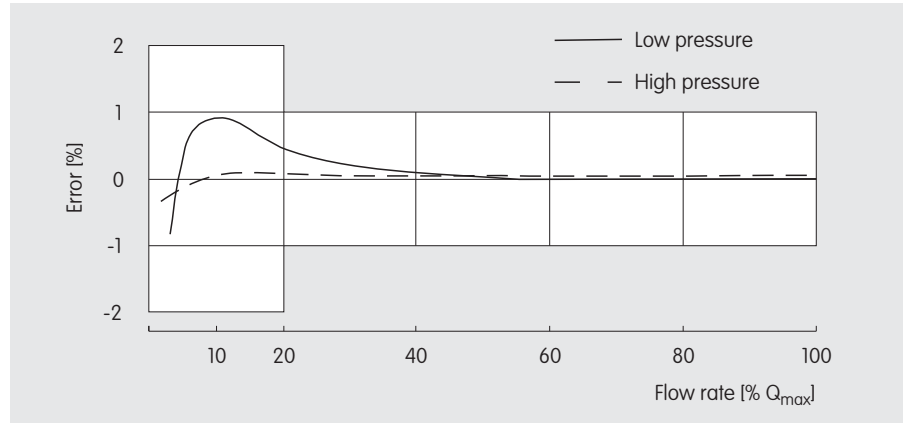

Measuring range

The low-pressure measuring range (atmospheric pressure) is 1:20 and optional 1:30 (see table with technical data).

When the actual pressure rises, the flow limit Q_{\min} becomes lower because of the increasing motive energy. The effective measuring range is therefore larger. $Q_{\min, HP}$ is shown in the table on the right. It should be noted that the permissible measuring ranges are defined by national regulations.

Meter size	Q_{\max} [m ³ /h]	$Q_{\min, LP}$ [m ³ /h]	Actual absolute pressure [bar]							
			5	10	15	20	25	30	35	40
G 65	100	5	$Q_{\min, HP}$ [m ³ /h]							
G 100	160	8	3	2	2	1	1	1	1	1
G 160	250	13	4	3	3	2	2	2	2	2
G 250	400	20	7	5	4	4	3	3	3	3
G 400	650	32	11	8	6	6	5	5	4	4
G 650	1000	50	17	12	10	9	8	7	7	6
G 1000	1600	80	27	19	16	13	12	11	10	10
			44	31	25	22	19	18	16	15

$$Q_{\min, HP} = Q_{\min, LP} \cdot \frac{1}{\sqrt{d_v \cdot p}}$$

d_v = density ratio of gas (natural gas $d_v = 0.65$)
 p = actual absolute pressure [bar]

Pressure loss

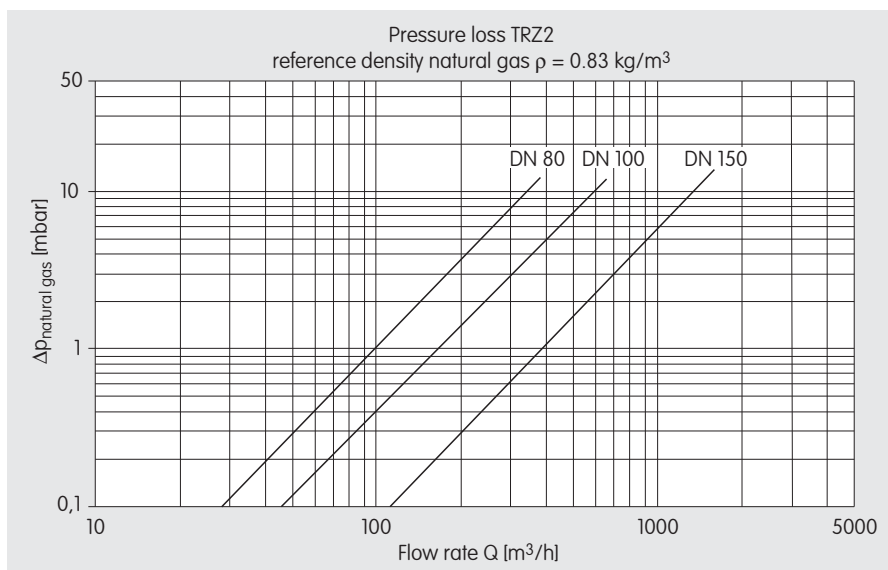

Pressure loss under operating conditions:

$$\Delta p_b = \Delta p_1 \cdot \rho_b$$

Density under operating conditions:

$$\rho_b = \rho_n \cdot \frac{p_b}{p_{atm}}$$

Pressure loss for any gas G:

$$\Delta p_G = \Delta p_{ng} \cdot \frac{\rho_G}{\rho_{ng}}$$

Sign	Description	Unit	Sign	Description	Unit
ρ_b	Density in operating condition	kg/m ³	p_b	Absolute operating pressure (overpressure)	kg/m ³
ρ_n	Density in standard condition	kg/m ³	Δp_1	Pressure loss for natural gas at 1 bar	kg/m ³
ρ_G	Density of any gas	kg/m ³	Δp_b	Pressure loss for natural gas at operating conditions	kg/m ³
ρ_{ng}	Density of natural gas	kg/m ³	Δp_{ng}	Pressure loss for natural gas	kg/m ³
p_{atm}	Absolute atmospheric pressure	bar	Δp_G	Pressure loss for any gas	bar

TRZ2: Turbine gas meters for custody transfer

Installation tips

Mounting position

According to EN 12261 Elster-Instromet turbine gas meters can be operated in horizontal and vertical position.

Inlet pipe: ≥ 2 DN independent of flow disturbance for DN 80 - 150,
 ≥ 5 DN for DN 50

Outlet pipe: Fitting in nominal width of the meter

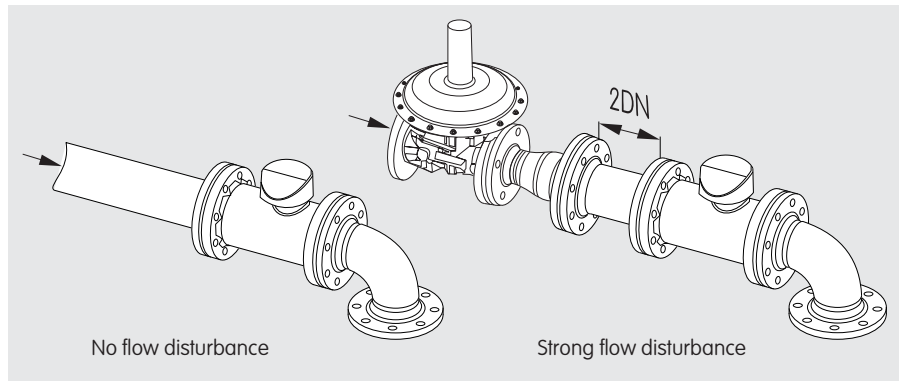

Technical data														
Measuring data	Diameter	DN	50	80	80	80	100	100	100	150	150	150	150	
	Meter size	G	65	100	160	250 *	160	250	400 *	250	400	650 *	1000 *	
	Measuring range	Q_{min}		5	8	13	20	13	20	32	20	32	50	80
		Q_{max}		100	160	250	400	250	400	650	400	650	1000	1600
	Δp ** at Q_{max}	[mbar]		11	2	5	12	2	5	13	1	2	6	15
Temperature	gas		- 20 °C to + 60 °C											
	ambient		- 20 °C to + 70 °C											
Housing ***	Pressure rates		PN 10, 16, 25, 40, 64, 100 / ANSI 150, 300, 600											
	Dimensions	A mm	165	215	215	215	273	273	273	356	356	356	356	
		B mm	155	172	172	172	185	185	185	210	210	210	210	
		C mm	150	240	240	240	300	300	300	450	450	450	450	
		D mm	75	100	100	100	120	120	120	180	180	180	180	
		E mm	135	157	157	157	170	170	170	193	193	193	193	
		F mm	280	200	200	200	210	210	210	235	235	235	235	
Weight [kg]***	PN10/16, ANSI150 (GGG)		10	21	21	21	29	29	29	53	53	53	53	
	PN25/40, ANSI300 (steel)		13	32	32	32	50	50	50	91	91	91	91	
	PN64/100, ANSI600 (steel)		15	33	33	33	50	50	50	97	97	97	97	
Outputs / pulse values *** [imp/m ³]	LF-type E1 (Reed switch)		10	1	1	1	1	1	1	1	1	1	1	
	HF-type AIR (inductive)		28000	10500	10500	10500	6630	6630	6630	6630	2560	2560	2560	
	HF-type AIS (inductive)		-	21000	21000	21000	13260	13260	13260	-	5120	5120	5120	

* Meter also available with measuring range 1:30

** Δp for natural gas at 1bar abs.

*** Small deviations are possible

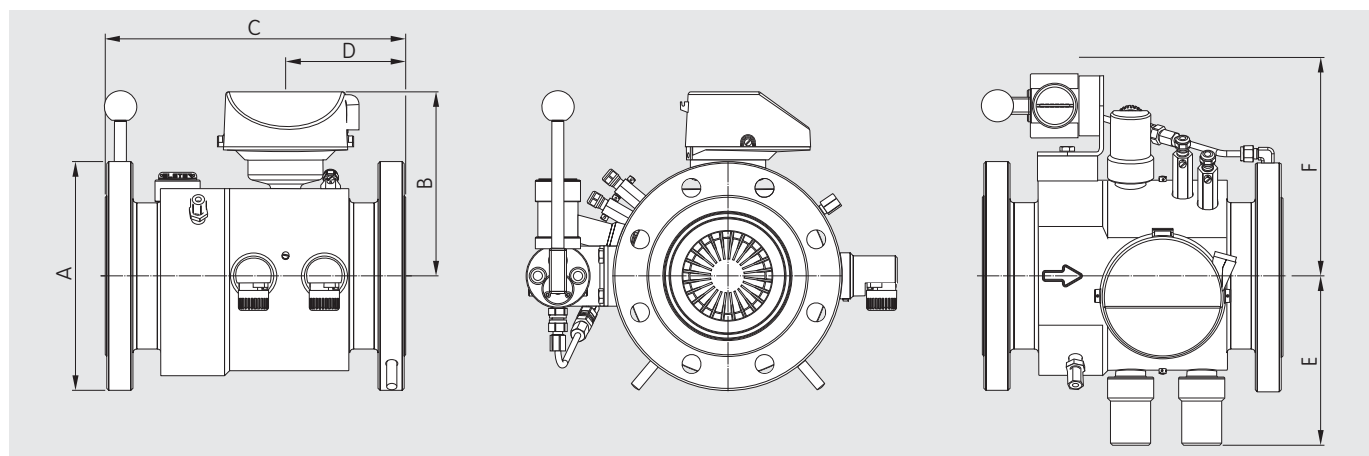

Your contacts

Germany
 Elster GmbH
 Steinern Str. 19 - 21
 55252 Mainz-Kastel
 T +49 6134 605 0
 F +49 6134 605 223
www.elster-instromet.com
info@elster-instromet.com

Belgium
 Elster-Instromet N.V.
 Rijkmakerlaan 9
 2910 Essen
 T +32 3 670 0700
 F +32 3 667 6940
www.elster-instromet.com
info@elster-instromet.com

Singapore
 Elster-Instromet Sdn. Bhd. (Singapore Branch)
 160 Paya Lebar Road
 #04-01 Orion@Paya Lebar
 Singapore 409022
 T +65 6247 7728
 F +65 6247 7729
sales@elster-instromet.com.sg

TRZ2 EN04

A20.08.2008