



**Štandardné vybavenie:**

- Napájacie napätie 230 V AC
- Svorkovnicové pripojenie
- 2 momentové spínače
- 2 polohové spínače
- Mechanické koncové dorazy
- Mechanické pripojenie prírubové ISO 5211
- Miestny ukazovateľ polohy
- Ručné ovládanie
- Stupeň krytia IP 67

**Standard equipment:**

- Voltage 230 V AC
- Terminal board connection
- 2 torque switches
- 2 position switches
- Mechanical stop ends
- Mechanical connection - flange ISO 5211
- Mechanical position indicator
- Manual control
- Protection code IP 67

**Špecifikačná tabuľka \Specification table\ SP 2.4**

Objednávaci kód \Order code\ 284. x - x x x x / x x

Klimatická odolnosť <sup>10)</sup> \Climate resistance\		Okolité teplota \Ambient temperature\	
Vyhovovanie \Version\	štandard \standard \	-25°C + +55°C	1
	štandard - C4 \standard - C4\	-25°C + +55°C	2
	chladné \cold \	-40°C + +40°C	3
	tropické \tropics\	-25°C + +55°C	6
	morské \sea\	-50°C + +55°C	7
	univerzálny \universal\	-50°C + +40°C	8

Elektrické pripojenie \Electric connection\	Napájacie napätie \Voltage\	Schéma zapojenia \Wiring diagram\	
Na svorkovnicu \To terminal board\	230 V AC	Z1a + Z11a	0
	220 V AC		L
	3x400 V AC	Z78a + Z12a <sup>8)</sup>	9
	3x400 V AC <sup>28)</sup>	Z303 + Z12a <sup>8)</sup>	2
	3x380 V AC	Z78a + Z12a <sup>8)</sup>	M
	3x380 V AC <sup>28)</sup>	Z303 + Z12a <sup>8)</sup>	N
	24 V AC	Z507a	3
	24 V DC	Z503a	A
Na konektor <sup>21)</sup> \To connector\	230 V AC	Z1a + Z11a	5
	220 V AC		P
	3x400 V AC	Z78a + Z12a <sup>8)</sup>	7
	3x400 V AC <sup>28)</sup>	Z303 + Z12a <sup>8)</sup>	6
	3x380 V AC	Z78a + Z12a <sup>8)</sup>	R
	3x380 V AC <sup>28)</sup>	Z303 + Z12a <sup>8)</sup>	S
	24 V AC	Z507a	8
	24 V DC	Z503a	C

Vypínací moment \Switching-off torque\	Max. zaťažovací moment \Max. load torque\	230 V, 220 V AC		3x380, 3x400 V AC, 24 V AC/DC			
		Doba prestavenia \Operating time\	Elektromotor \Electric motor\	Doba prestavenia \Operating time\	Elektromotor \Electric motor\		
575 Nm	500 Nm	40 s/90°	60 W	40 s/90°	65 W, AC/DC	90 W, 3x400 V AC	0
		80 s/90°		80 s/90°	-	-	1
		160 s/90°	20 W	-	-	-	2

Pracovný uhol \Operating angle\		
S pevnými dorazmi \With stop ends\	60°	A
	90°	B
	120°	C
	160°	D
Bez dorazov \Without stop ends\	60°	K
	90°	L
	120°	M
	160°	N
	360°	P
	> 0°Ł 360° <sup>41)</sup>	Z

Pokračovanie na ďalšej strane \Next page\

Objednávací kód \ Order code \ 284. x - x x x x x x / x x

Vysielač polohy \ Transmitter \		Zapojenie \ Connection \	Výstup \ Output \	Schéma zapojenia \ Wiring diagram \			
Bez vysielača \ Without transmitter \		-	-	-	A		
Odporový \ Potentiometer \	Jednoduchý \ Single \	-	1 x 100 W	Z5a	B		
			1 x 2 000 W		F		
	Dvojitý \ Double \		2 x 100 W	Z6a	K		
			2 x 2 000 W		P		
Elektronický - prúdový \ Electronic position transmitter \	Bez zdroja \ Passive \	2-vodič \ 2-wire \	4 - 20 mA	Z10a	S		
		3-vodič \ 3-wire \	0 - 20 mA	Z257a	T		
			4 - 20 mA		V		
			0 - 5 mA		Y		
	So zdrojom <sup>59)</sup> \ Active \	2-vodič \ 2-wire \	4 - 20 mA	Z269a	Q		
		3-vodič \ 3-wire \	0 - 20 mA	Z260a	U		
			4 - 20 mA		W		
			0 - 5 mA		Z		
		Prúdový \ CPT \	Bez zdroja \ Passive \	2-vodič \ 2-wire \	4 - 20 mA	Z10a	I
			So zdrojom \ Active \ <sup>59)</sup>		Z269a	J	

Mechanické pripojenie \ Mechanical connection \	Tvar pripoj. dielca \ Coupling shape \			Rozmerový náčrt \ Dimensional drawing \		
	ISO	Regada	Rozmer \ Dimension \			
Príruba \ Flange \ - ISO 5211	F10/F12	D-27	A04	27x27 <sup>62)</sup>	P-1147 P-1222	A
		L-27	B04			B
		H-27	C08			27x48 <sup>62)</sup>
		V-50	D08	Ø50 <sup>62)</sup>		D
		D-22	A03	22x22 <sup>62)</sup>		E
		L-22	B03			F
		H-22	C06	22x32 <sup>62)</sup>		G
		V-42	D06	Ø42		H
		-	-	- <sup>65)</sup>		M
		H-16	C07	16x22 <sup>62)</sup>		N
		H-19	C09	19x28 <sup>62)</sup>		P
		V-45.4	D07	Ø45.4 <sup>63)</sup>		V
Stojan, výstupný hriadeľ, pero \ Stand, Output shaft, Key \	-	E04	Ø50	P-1395, P-1412 P-1413/B	J	
Stojan + Páka \ Stand + Lever \	-	-	-		K	
Stojan + Páka + Ťahadlo TV 50-1/25 \ Stand + Lever + Pull-rod TV 50-1/25 \	-	-	-		L	

Rozšírené vybavenie \ Additional equipment \		Schémy zapojenia \ Wiring diagrams \					
		230 V AC	3x400 V AC	24 V AC	24 V DC		
A	2 prídavné polohové spínače \ 2 additional position switches \	Z11a	Z12a	Z507a	Z503a	0	0
E	Vyhrievací odpor s tepelným spínačom \ Space heater with thermal switch \	Z1a	Z78a	Z507a	Z503a	0	2
C	Miestne ovládanie \ Electric local controls <sup>70)</sup> \	Z270i	Z90c, Z304a	Z509a	Z505a	0	7
D	Vyhrievací odpor \ Space heater \	Z1a	Z78a	Z507a	Z503a	1	5
H	Pozlátené kontakty mikrospínačov, detaily po konzultácii s výrobcom \ Gold coated contacts of microswitches, details after consultation with producer \					4	0
Dovolené kombinácie a kódy \ Allowed combination and code \: A+E=04, A+C=08, E+C=10, A+E+C=12, A+D=16, C+D=17, A+C+D=18							

**Poznámky:**

- 8) Pre vyhotovenie s prídavnými polohovými spínačmi je možné špecifikovať dvojitý vysielač len bez vyhrievacieho odporu.
- 10) Pozri "Pracovné prostredia" na str. 2.
- 21) Vyhrotenie s konektorom len do -40° C. Schémy zapojenia sú uvedené bez číselného označenia na konektore. Úplná schéma na požiadanie.
- 28) Vyhrotenie s reverzačnými stýkačkami.
- 33) Týmto momentom je možné zaťažovať servopohon v režime S2-10 min, resp. S4-25%, 6-90 cyklov/hod. Pre regulačnú prevádzku s režimom S4-25%, 90 až 1200 cyklov/hod je tento moment rovný 0.8 násobku max. zaťažovacieho momentu.
- 34) Odchýlka doby prestavenia pre DC elektromotory je -50% až +30% v závislosti od záťaže. Pre iné napätia je ± 10%.
- 41) Platí len pre vyhotovenie bez vysielača.
- 59) Pre napájacie napätie 24 VAC/DC po dohode s výrobcom.
- 62) Pripojovací otvor priamo vo výstupnom hriadeľi ( bez výmennej vložky ).
- 63) Otvor pre výmennú vložku.
- 65) Výmenná vložka. Tvar otvoru pripojovacieho dielca podľa dohody.
- 70) Local controls module only till -25°C.

**Notes:**

- 8) For the EA version with additional position switches a double potentiometer cannot be specified.
- 10) See "Working environment" on page 2.
- 21) The version with connector in -40°C only. Wiring diagrams are not showing connector pin numbers. Complete diagram on request.
- 28) Version with reverse contacts.
- 33) By this torque it is possible to load the actuator under duty cycle S2-10 min, or S4-25%, 6-90 cycles per hour. For duty cycle S4-25%, 90-1200 cycles per hour this torque equals max. load torque multiplied by 0.8.
- 34) Deviation of operating speed for the DC electric motor is from -50% up to +30% depending on load. For other voltages the deviation is ± 10%.
- 41) Valid for version without transmitter only.
- 59) Active position transmitter for version 24 V AC/DC only after agreement with producer.
- 62) Connection bore directly within output shaft (without replaceable insert).
- 63) Bore for replaceable insert.
- 65) Replaceable insert. Profile of hole in connecting part on request.
- 70) Local controls module only till -25°C.

**Schémy zapojenia \ Wiring diagrams \ SP 2.4**

Pozri str. 34, 35 \ See pages 34, 35 \

**Elektrické pripojenie:**

na svorkovnicu s 24 svorkami s prierezom pripojovacích vodičov 2,5 mm<sup>2</sup>, cez 2 kábelové vývodky M20x1,5 pre priemer kábla 8 až 14,5 mm.

**Electric connection:**

to terminal board with 24 terminals, wire cross section 2.5 mm<sup>2</sup>, via 2 cable glands M20x1.5 for cable diameter 8 to 14.5 mm.

Schémy zapojenia Wiring diagrams \ SP 1, SP 2, SP 2.3, SP 2.4

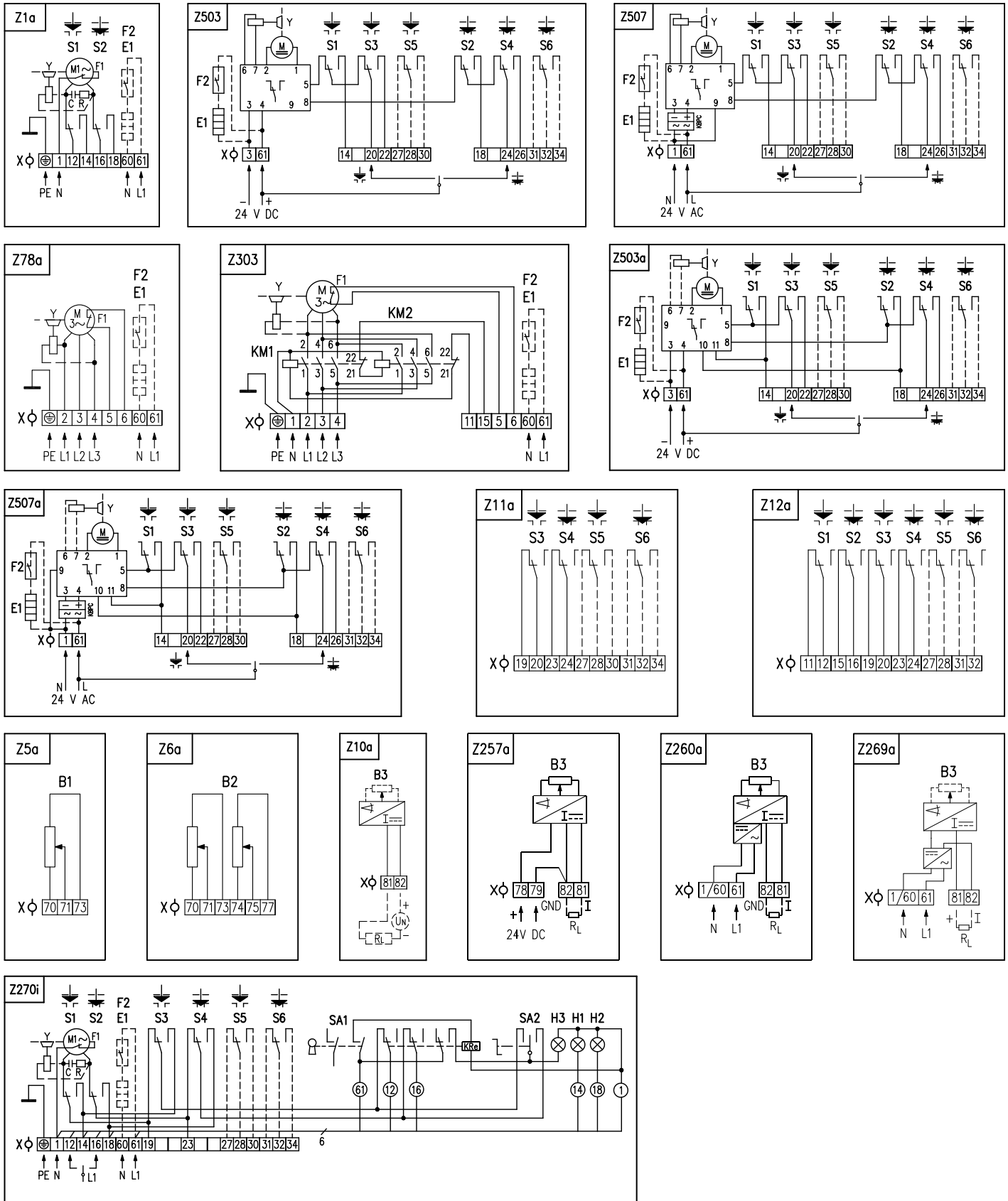

**Poznámky:**

1. Zapojenie je limitované počtom svoriek 24 na svorkovnici servopohonu.
2. Elektromotory sú štandardne vybavené tepelnou ochranou.
3. Vo vyhotovení ES s napájacím napätím 24 V AC nie je potrebné pripojiť zemiaci vodič PE.
4. Iné zapojenia servopohonov ako sú uvedené v katalógu sú možné po dohode s výrobcom.

**Notes:**

1. Wiring connection is limited by max. number of 24 terminals.
2. Electric motors are equipped with thermal protection as standard.
3. The version of EA with supply voltage of 24V AC does not require connecting of an earthing cable PE.
4. Different wirings of actuators than shown in the catalogue are possible after agreement with producer.

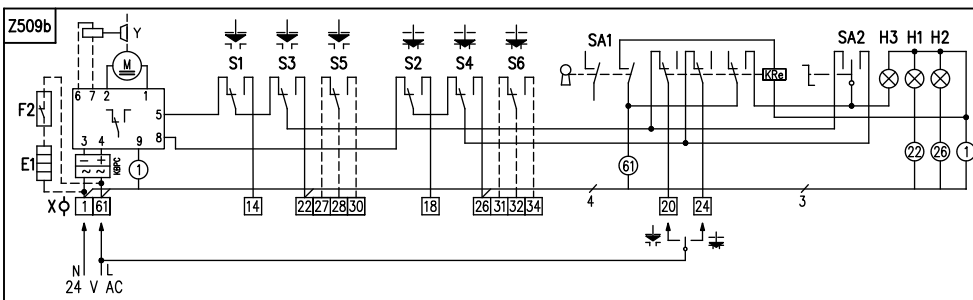
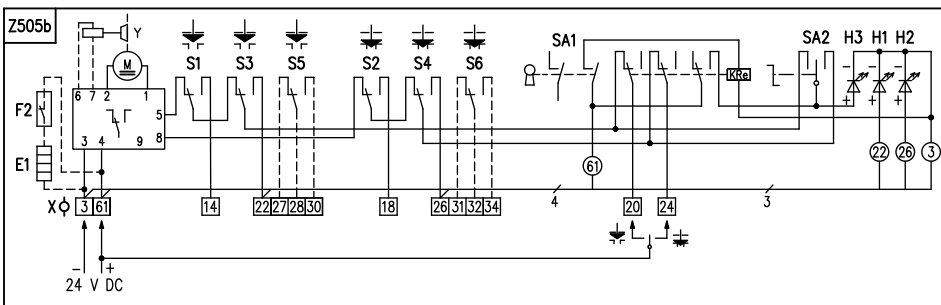
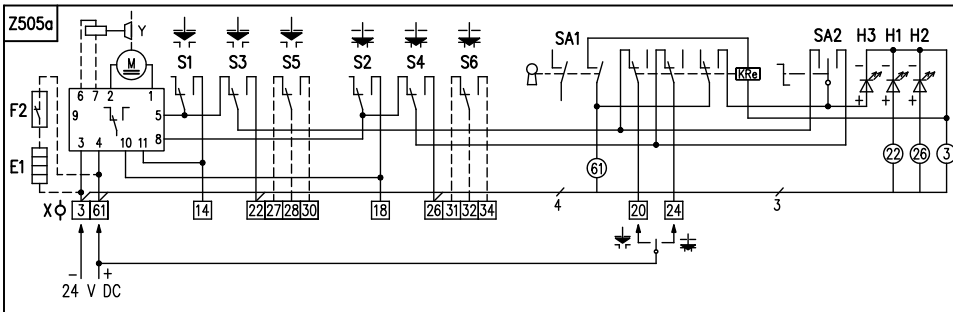
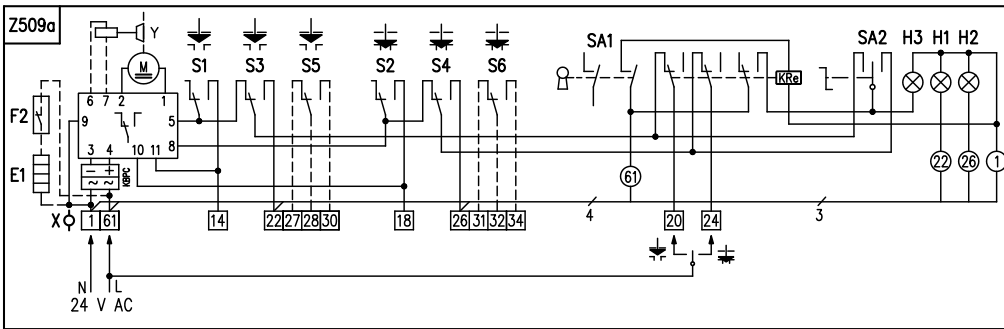
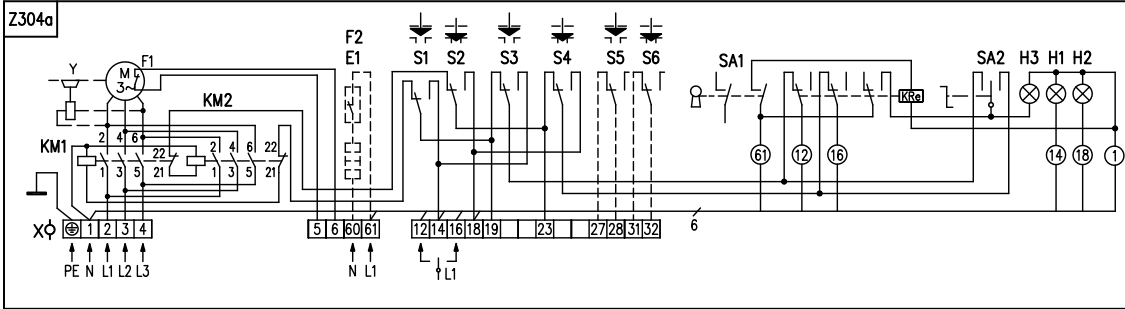
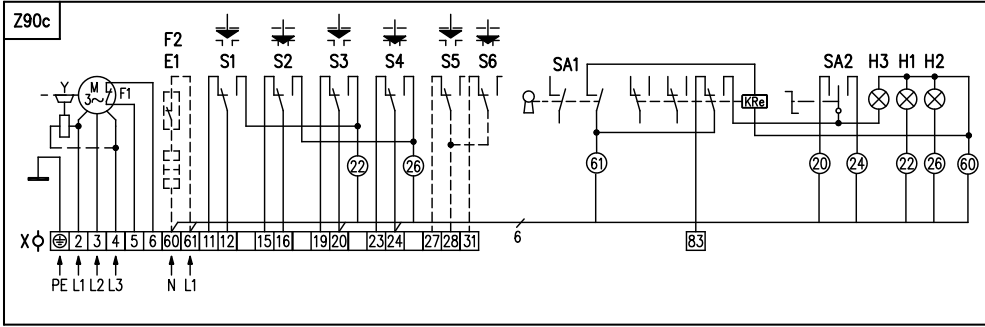

**Legenda:**

Z1a .....zapojenie 1-fázového elektromotora  
 Z5a .....zapojenie jednoduchého odporového vysieláča polohy  
 Z6a .....zapojenie dvojitého odporového vysieláča polohy  
 Z10a .....zapojenie polohového vysieláča prúdového - 2-vodič bez zdroja  
 Z11a .....zapojenie polohových spínačov pre 1-fázový elektromotor  
 Z12a .....zapojenie polohových spínačov pre 3-fázový elektromotor  
 Z78a .....zapojenie 3-fázového elektromotora  
 Z90c .....zapojenie 3-fázového elektromotora s miestnym ovládaním  
 Z257a .....zapojenie el. polohového vysieláča prúdového - 3-vodič bez zdroja  
 Z260a .....zapojenie el. polohového vysieláča prúdového - 3-vodič so zdrojom  
 Z269a .....zapojenie polohového vysieláča prúdového - 2-vodič so zdrojom  
 Z270i .....zapojenie 1-fázového elektromotora s miestnym ovládaním  
 Z303 .....zapojenie 3-fázového elektromotora s reverzačnými stýkačami  
 Z304a .....zapojenie 3-fázového elektromotora s reverzačnými stýkačami a miestnym ovládaním  
 Z503 .....zapojenie SP 1 s ektromotorom 24 V DC  
 Z503a .....zapojenie SP 2, SP 2.3, SP 2.4 s ektromotorom 24 V DC  
 Z505a .....zapojenie SP 2, SP 2.3, SP 2.4 s ektromotorom 24 V DC s miestnym ovládaním  
 Z505b .....zapojenie SP 1 s ektromotorom 24 V DC s miestnym ovládaním  
 Z507 .....zapojenie SP 1 s ektromotorom 24 V AC  
 Z507a .....zapojenie SP 2, SP 2.3, SP 2.4 s ektromotorom 24 V AC  
 Z509a .....zapojenie SP 2, SP 2.3, SP 2.4 s ektromotorom 24 V AC s miestnym ovládaním  
 Z509b .....zapojenie SP 1 s ektromotorom 24 V AC s miestnym ovládaním

B1 .....odporový vysieláč jednoduchý  
 B2 .....odporový vysieláč dvojitý  
 B3 .....polohový vysieláč prúdový  
 S1 .....momentový spínač „otvorené“  
 S2 .....momentový spínač „zatvorené“  
 S3 .....polohový spínač „otvorené“  
 S4 .....polohový spínač „zatvorené“  
 S5 .....prídavný polohový spínač „otvorené“  
 S6 .....prídavný polohový spínač „zatvorené“  
 M .....elektromotor  
 C .....kondenzátor  
 Y .....brzda elektromotora  
 E1 .....vyhrievací odpor  
 F1 .....tepelná ochrana elektromotora  
 F2 .....tepelný spínač vyhrievacieho odporu  
 X .....svorkovnica  
 I .....výstupný signál prúdový  
 H1 .....indikácia koncovej polohy „otvorené“  
 H2 .....indikácia koncovej polohy „zatvorené“  
 H3 .....indikácia režimu „miestne ovládanie“  
 SA1 .....otočný prepínač s kľúčom „dialkové - 0 - miestne“ ovládanie  
 SA2 .....otočný prepínač „otvára - stop - zatvára“  
 R .....zrážací odpor  
 R<sub>L</sub> .....zaťažovací odpor  
 KM .....reverzný stýkač

**Legend:**

Z1a .....connection of 1-phase electric motor  
 Z5a .....connection of single potentiometer  
 Z6a .....connection of double potentiometer  
 Z10a .....connection of CPT or electronic position transmitter - 2 - wire, passive  
 Z11a .....connection of position switches for 1-phase electric motor  
 Z12a .....connection of position switches for 3-phase electric motor  
 Z78a .....connection of 3-phase electric motor  
 Z90c .....connection of 3-phase electric motor with local controls  
 Z257a .....connection of electronic position transmitter - 3 - wire, passive  
 Z260a .....connection of electronic position transmitter - 3 - wire, active  
 Z269a .....connection of CPT or electronic position transmitter - 2 wire - active  
 Z270i .....connection of 1-phase electric motor with local controls  
 Z303 .....connection of 3 - phase electric motor with reverse contactors  
 Z304a .....connection of 3 -phase electric motor with reverse contactors and with local controls  
 Z503 .....conection of SP 1 with electric motor 24 V DC  
 Z503a .....conection of SP 2, SP 2.3, SP 2.4 with electric motor 24 V DC  
 Z505a .....conection of SP 2, SP 2.3, SP 2.4 with electric motor 24 V DC with local controls  
 Z505b .....conection of SP 1 with electric motor 24 V DC with local controls  
 Z507 .....conection of SP 1 with electric motor 24 V AC  
 Z507a .....conection of SP 2, SP 2.3, SP 2.4 with electric motor 24 V AC  
 Z509a .....conection of SP 2, SP 2.3, SP 2.4 with electric motor 24 V AC with local controls  
 Z509b .....conection of SP 1 with electric motor 24 V AC with local controls

B1 .....single potentiometer  
 B2 .....double potentiometer  
 B3 .....CPT or electronic position transmitter  
 S1 .....torque switch „open“  
 S2 .....torque switch „closed“  
 S3 .....position switch „open“  
 S4 .....position switch „closed“  
 S5 .....additional position switch „open“  
 S6 .....additional position switch „closed“  
 M .....electric motor  
 C .....capacitor  
 Y .....motor's brake  
 E1 .....space heater  
 F1 .....motor's thermal protection  
 F2 .....space heater's thermal switch  
 X .....terminal board  
 I .....output current signal  
 H1 .....indication of „open“ limit position  
 H2 .....indication of „closed“ limit position  
 H3 .....indication of „electric local control“  
 SA1 .....rotary switch with key „remote - 0 - electric local“ control  
 SA2 .....rotary switch „opening - stop - closing“  
 R .....reducing resistor  
 R<sub>L</sub> .....loading resistor  
 KM .....reverse contactor

Rozmerové náčrty \Dimensional drawings\ SP 1, SP 2, SP 2.3, SP 2.4

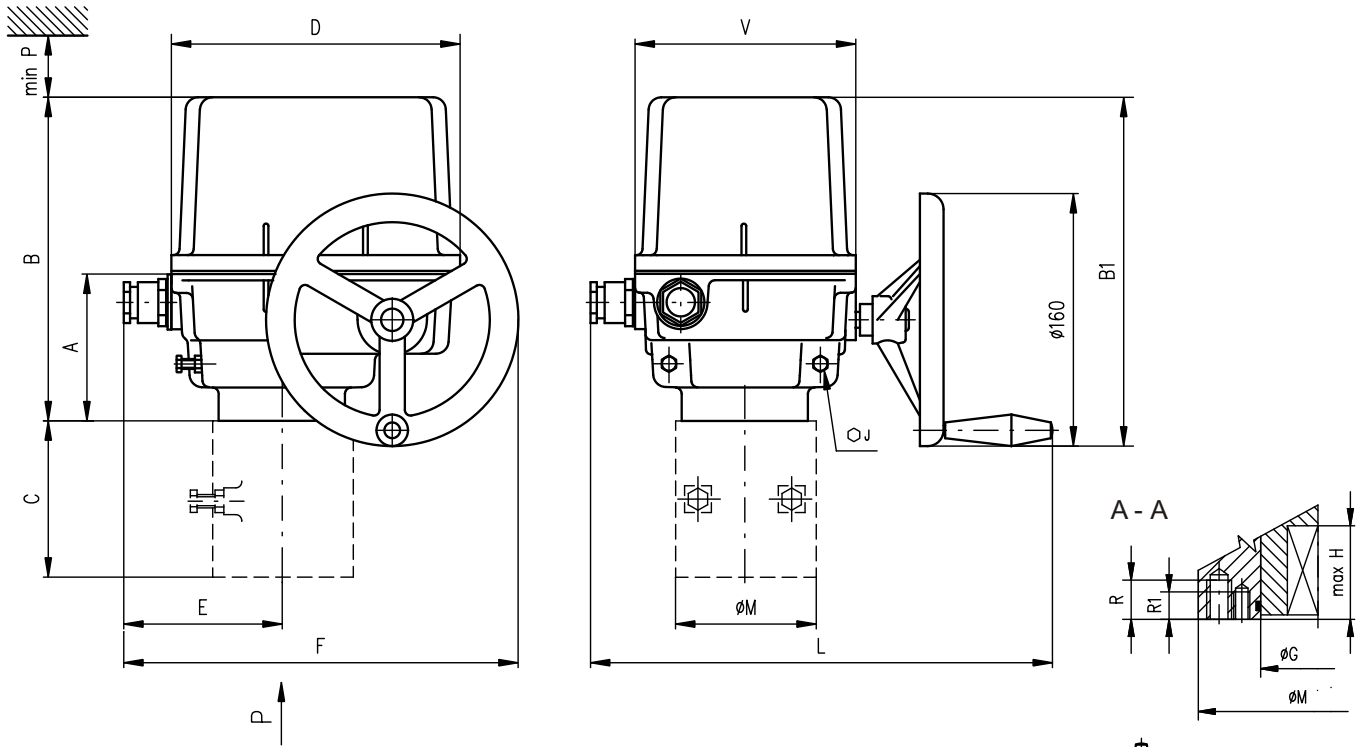

Hlavné rozmery \Main dimensions\

Typ \Type\	A	B	B1	C	D	E	F	J	L	M	P	V
SP 1	102	223	239	-	183	93	243	13	280 396*	90	160	140
SP 2	117	284	291	-	234	119	294	17	330 446*	90	210	190
SP 2.3				112				125				
SP 2.4				127				150				

\* platí pre vyhotovenie s konektorom \valid for version with a connector\

Rozmery prírub \Flange dimensions\

Typ \Type\	G	H	R	R1	S	S1	T	T1	Veľkosť príruby \Flange size\
SP 1	40	37	16	12	70	50	M8	M6	F07/F05
SP 2	40	49	16	12	70	50	M8	M6	F07/F05
SP 2.3	55	56	20	16	102	70	M10	M8	F10/F07
SP 2.4	65	71	24	20	125	102	M12	M10	F12/F10

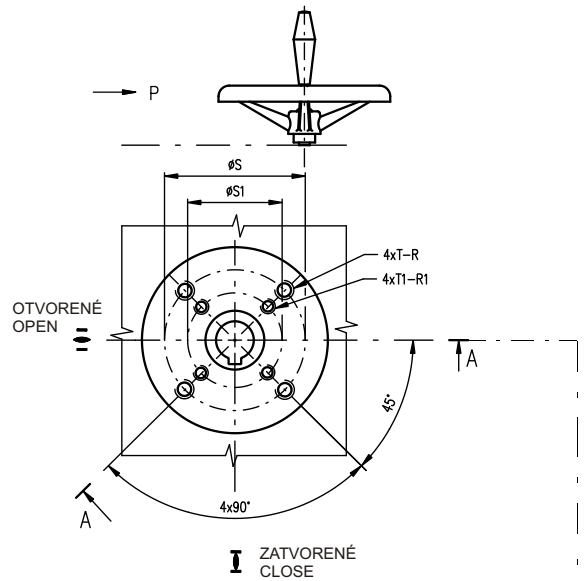

Tvar pripojovacieho dielca \Coupling shape\													
D-xx (Axx)			L-xx (Bxx)			H-xx (Cxx)			V-xx (D01 - D09)			V-30 (D10)	
ISO	Regada	Rozmer \Dimension\	ISO	Regada	Rozmer \Dimension\	ISO	Regada	Rozmer \Dimension\	ISO	Regada	Rozmer \Dimension\		
D-xx	Axx	U	L-xx	Bxx	U	H-xx	Cxx	U V	V-xx	Dxx	W	Z	X
D-14	A01	14	L-14	B01	14	H-14	C01	14 22	V-20	D01	20.0	22.5	6.0
D-17	A02	17	L-17	B02	17	H-11	C02	11 18	V-22	D02	22.0	24.5	6.0
D-22	A03	22	L-22	B03	22	H-8	C03	8 13	V-32.2	D03	32.2	35	6.5
D-27	A04	27	L-27	B04	27	H-17	C04	17 25	V-17	D04	17.0	19.5	6.0
D-11	A05	11	L-11	B05	11	H-13	C05	13 19	V-28	D05	28.0	30.9	8.0
D-16	A06	16	L-16	B06	16	H-22	C06	22 32	V-42	D06	42.0	45.1	12.0
						H-16	C07	16 22	V-45.4	D07	45.4	48.8	10.0
						H-27	C08	27 48	V-50	D08	50.0	53.5	14.0
						H-19	C09	19 28	V-18	D09	18.0	20.5	6.0
						H-10	C10	10 16	V-30	D10	30.0	32.5	8.0

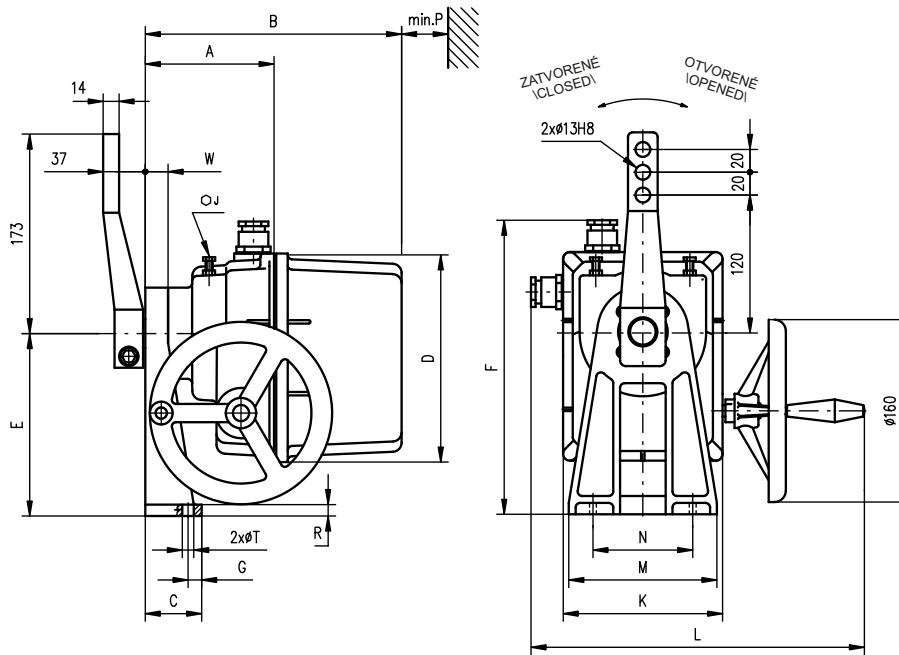

P - 1162

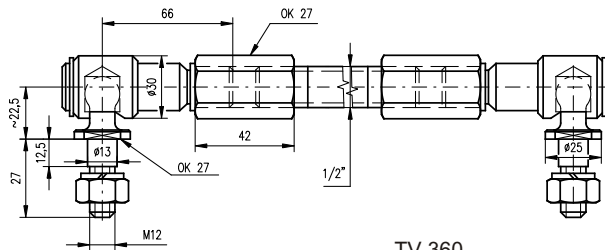

P - 0210

Tvar pripojovacieho dielca \Coupling shape\

Typ \Type\	H	S	U	V	Z	Y	Y1	Tvar pripojovacieho dielca \Coupling shape\
SP 1	24.5	22	6	28	25	2	2	E01
SP 2	27.9	25	8	35	28	2	2	E02

Hlavné rozmery \Main dimensions\

Typ \Type\	A	B	C	D	E	E1	F	F1	F2	G	W	J	K	L	M	N	P	R	T
SP 1	122	243	50	183	160	163	258	313	273 345*	12	20	13	140	280 396*	130	80	160	10	10.5
SP 2	132	288	58	232	200	189	323	364	-	30	28	17	190	330 446*	160	90	210	11	12.6

\* platí pre vyhotovenie s konektorom \valid for version with a connector\

Vyhotovenie s miestnym ovládaním \Version with local control\

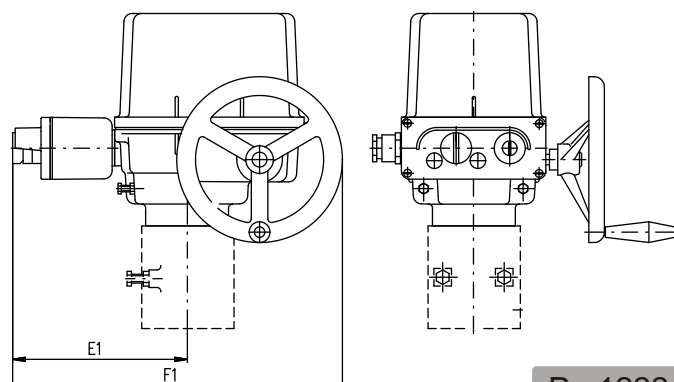

P - 1222

Vyhotovenie s miestnym ovládaním \Version with local control\

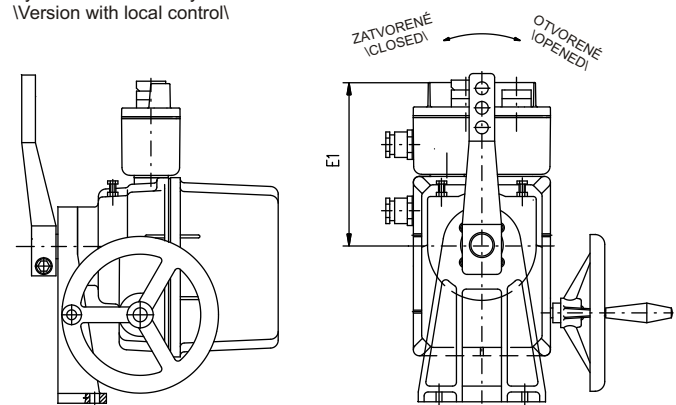

P - 1225

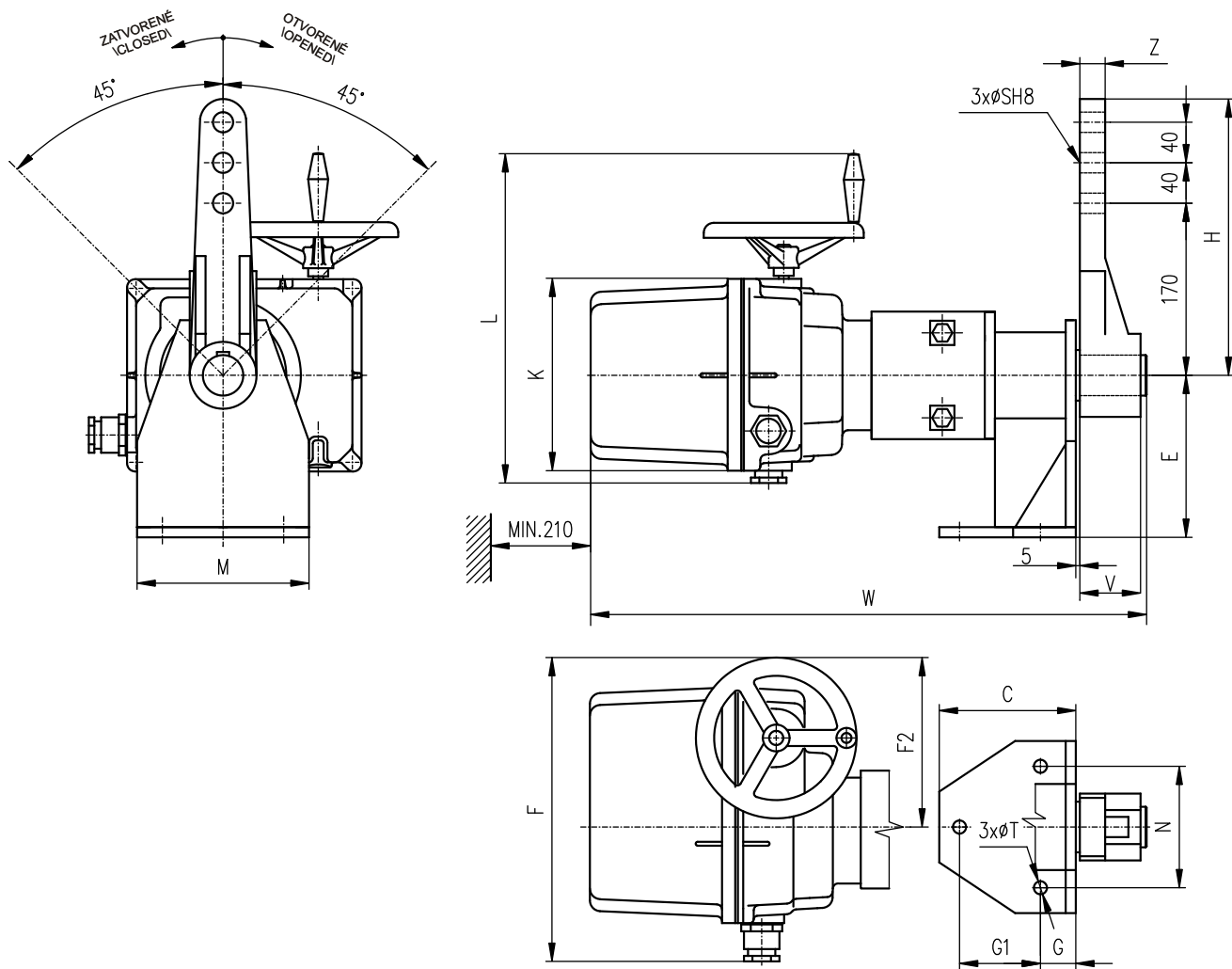

Hlavné rozmery \Main dimensions\

Typ \Type\	C	E	F	F2	G	G1	H	W	K	L	M	N	S	T	V	Z
SP 2.3	135	160	294	174	35	80	278	532	190	330 446*	170	120	20	13	56	25
SP 2.4	200	220	294	174	60	120	278	593	190	330 446*	228	170	25	17	80	30

\* platí pre vyhotovenie s konektorom \valid for version with a connector\

P - 1395

Vyhotovenie pákového servopohonu SP 2.3 a SP 2.4 s miestnym ovládaním  
 \Version SP 2.3, SP 2.4 with lever and local controls\

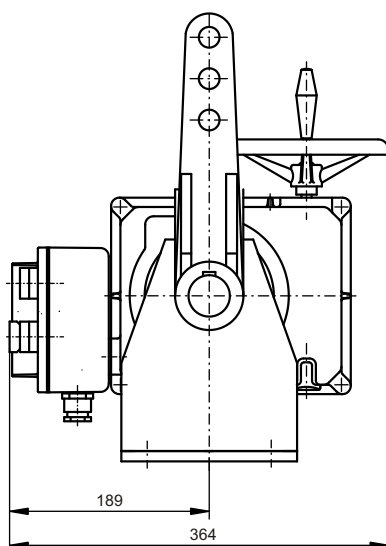

P - 1412



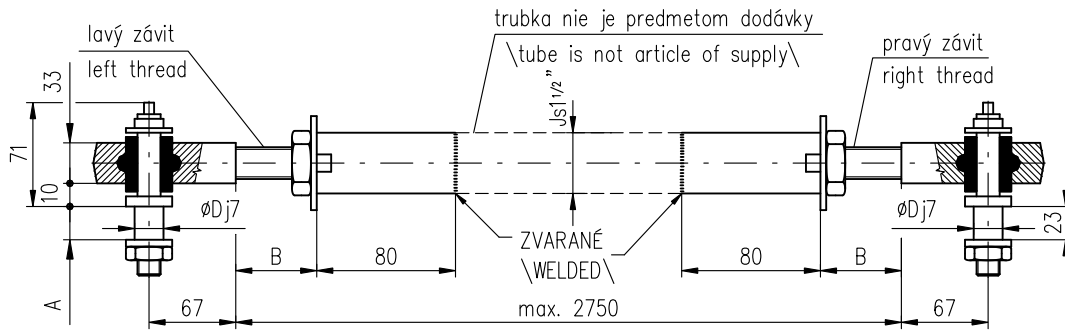

P-1413/B	SP 2.4	TV 50-1/25	28	Min.30	25
P-1413/A	SP 2.3	TV 40-1/20	23	Max.50	20
Vyhotovenie \Version\	Typ \Type\	Typ ťahadla \Pull-rod version\	A	B	D

P - 1413

Vyhotovenie servopohonu SP 2.3 a SP 2.4 so stojanom a voľným koncom hriadeľa  
 \Version SP 2.3, SP 2.4 with stand and naked shaft\

Tvar pripojovacieho dielca \Coupling shape\

Typ \Type\	H	S	U	V	Z	Y	Y1	Tvar pripojovacieho dielca \Coupling shape\
SP 2.3	43.1	40	12	66	56	4	7	E03
SP 2.4	53.8	50	16	82	70	4	7	E04