

Bourdon Tube Pressure Gauge Model 213.40, with Liquid Filling and Forged Brass Case

WIKA Data Sheet PM 02.06



Applications

- Intended for adverse service conditions where pulsating or vibration exists
- Suitable for all gaseous and liquid media that will not obstruct the pressure system or attack copper alloy parts
- Mining industry
- Hydraulics
- Shipping industry

Special Features

- Vibration- and shock resistant
- Robust pressure gauge
- Approval German Lloyd
- Scale ranges up to 0 ... 1000 bar



Bourdon Tube Pressure Gauge Model 213.40,
radial connection

Description

Design

EN 837-1

Nominal size

63 and 100 mm

Accuracy class

NS 63: 1.6

NS 100: 1.0

Scale range

NS 50: 0 ... 1 up to 0 ... 600 bar

NS 63, 80, 100: 0 ... 0,6 up to 0 ... 1000 bar

Or other equivalent units of pressure or vacuum.

Working pressure

NS 63: Steady: $\frac{3}{4}$ x of full scale range

Fluctuating: $\frac{2}{3}$ x of full scale range

Short time: full scale range

NS 100:

Steady:

full scale range

Fluctuating:

0,9 x full scale range

Short time:

1,3 x full scale range

Operating temperature

Ambient: -20 ... +60 °C

Medium: +60 °C maximum

Temperature effect

When temperature of the pressure element deviates from reference temperature (+20 °C):

Max. ± 0.3 %/10 K of true scale value.

Ingress of protection

IP 65 (EN 60 529 / IEC 529)

Pressure connection

Material: brass forging

NS 63: G $\frac{1}{4}$ B, 14 mm flats

NS 100: G $\frac{1}{2}$ B, 22 mm flats

Pressure element

NS 63:
 < 60 bar: Cu-alloy, C-type, soft soldered
 ≥ 60 bar: Cu-alloy, helical type, soft soldered
 NS 100:
 < 100 bar: Cu-alloy, C-type, soft soldered
 ≥ 100 bar: stainless steel 1.4571, helical type, brazed

Movement

Cu-alloy

Dial

NS 63: white plastic, with pointer stop pin
 NS 100: white aluminium
 With black lettering

Pointer

Black aluminium

Window

Non-splintering clear acrylic glass

Case

Solid brass forging with integral entry stem
 Pressure relief in case top
 Ranges ≤ 0 ... 16 bar with case venting provision
 Ranges < 0 ... 6 bar fully sealed

Bezel ring

Roll formed stainless steel

Liquid filling

Glycerine 99,7 %

Optional extras

- Other pressure connection
- Internal pressure compensation
- Medium temperature up to 100°C with special soft solder
- 3-hole surface or panel mounting flange
- Triangular bezel with clamp

Dimensions in mm

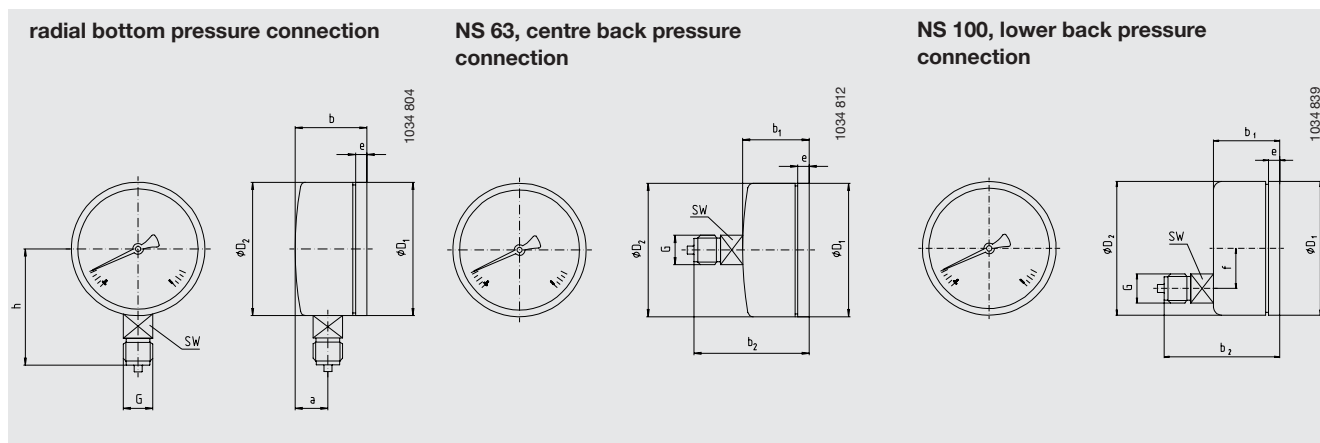

NG	Dimension in mm											Weight in kg
	a	b	b ₁	b ₂	D ₁	D ₂	e	f	G	H ± 1	SW	
63	12	36	36	56	62	62	10.5	-	G ¼ B	54	14	0.30
100	13.5	53.5	53.5	86	99	99	11.5	30	G ½ B	87	22	1.10

Standard pressure entry with parallel thread and sealing to EN 837-1 / 7.3

Ordering information

Pressure gauge model / Nominal size / Scale range / Location and size of connection / Optional extras required

Specifications and dimensions given in this leaflet represent the state of engineering at the time of printing. Modifications may take place and materials specified may be replaced by others without prior notice.

